

## ENKELFAN EEC

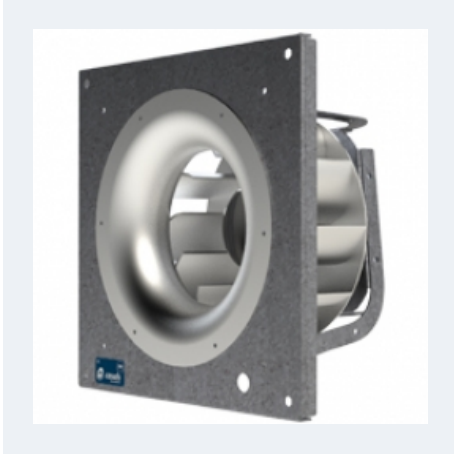

### CENTRIFUGAL FAN WITH EXTERNAL ROTOR EC MOTOR

#### MANUFACTURING FEATURES

Plug-type fan with self-cleaning impeller with back curved blades (backward), high performance and single inlet, direct driven. Dynamically balanced to minimize noise and vibration. Polyamide reinforced impeller for models 155 and 190 and aluminum plate for the rest.

High efficiency, low noise external rotor EC motor. Speed control through a 0-10V or PWM signal. Single-phase 230V 50 / 60Hz power supply for models 155 to 310 and three-phase 400V 50 / 60Hz for sizes 355 to 630. IP54 motor and class B insulation.

Frame and motor support arms made of galvanized steel.

#### APPLICATIONS

Ideal to integrate in air conditioners, plenums, compressors, dryers, booths, photovoltaic inverters.

Working temperature range from -20°C to 60°C for models size 155-310, -25°C to 60°C for 355-450 sizes, -30°C to 50°C for size 500 and -30°C to 40°C for 560 and 630 models.

#### UNDER REQUEST

- Fan (size between 250 and 450) with k-factor reading.

## Accessories



PMR



REGC

## Technical data

### Single-phase motor

Code	Model	R.P.M.	Rated I. A 230V	Rated power kW	Max. Airflow m <sup>3</sup> /h	Sound db (A)**	Weight kg	Connect. diagram
ENKEC155	ENKELFAN 155 EEC	3950	0,25	0,06	460	-	3	1
ENKEC190	ENKELFAN 190 EEC	3570	0,6	0,09	760	-	4,50	1
ENKEC250	ENKELFAN 250 EEC	2500	1,00	0,15	1.640	-	7,50	1
ENKEC310	ENKELFAN 310 EEC	2350	1,7	0,36	3.160	-	13	2

### Three-phase motor

Code	Model	R.P.M.	Rated I. A 400V	Rated power kW	Max. Airflow m <sup>3</sup> /h	Sound db (A)**	Weight kg	Connect. diagram
ENKEC355	ENKELFAN 355 EEC	2100	1,63	0,99	4.890	-	17,50	3
ENKEC450	ENKELFAN 450 EEC	1450	1,67	1,01	6.955	-	26	3
ENKEC500	ENKELFAN 500 EEC	1800	4,95	3,00	13.850	-	40	4
ENKEC560	ENKELFAN 560 EEC	1520	4,4	2,77	16.100	-	48	4
ENKEC630	ENKELFAN 630 EEC	1250	4,4	2,70	18.600	-	53	4

**Notes:**

\*\* Total sound pressure level at the point of maximum flow measured in dB(A) in the suction measured in free field at a distance of 6m from the source

## Dimensions

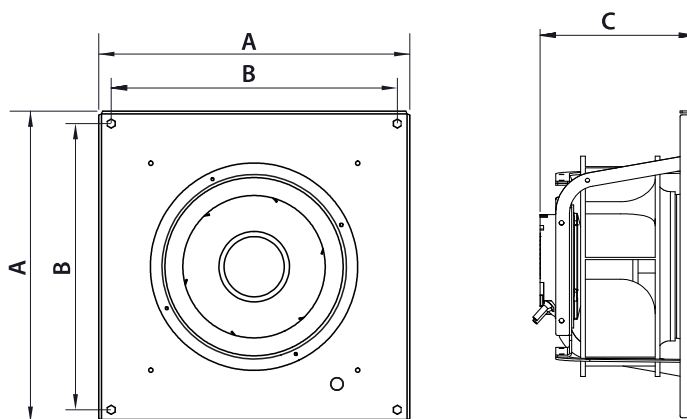

Model	A	B	C
ENKELFAN 155 EEC	220	184	106.5
ENKELFAN 190 EEC	280	244	106.5
ENKELFAN 250 EEC	355	319	200
ENKELFAN 310 EEC	450	414	223.7
ENKELFAN 355 EEC	500	454.8	321.5
ENKELFAN 450 EEC	630	583	381
ENKELFAN 500 EEC	710	650	520.5
ENKELFAN 560 EEC	800	730	540
ENKELFAN 630 EEC	900	810	580

## Wiring diagram

### Wiring diagram N° 1

Nº	Signal Señal	Colour Color	Specification Especificación
1	L	Brown Marrón	AC 220V/50Hz
2	N	Blue Azul	AC 220V/50Hz
3	Pe	Yellow-Green Amarillo-Verde	

Nº	Signal Señal	Colour Color	Specification Especificación
1	GND	Blue Azul	
2	Vsp	Yellow Amarillo	0-10 V/PWM
3	Vcc	Red Rojo	DC 10V
4	FG	White Blanco	1 Pulse/R

### Wiring diagram N° 2

Nº	Signal Señal	Colour Color	Specification Especificación
1	L	Brown Marrón	AC 220V-50/60 Hz
2	N	Blue Azul	AC 220V-50/60 Hz
3	Pe	Yellow-Green Amarillo-Verde	

Nº	Signal Señal	Colour Color	Specification Especificación
1	GND	Blue Azul	
2	Vsp	Yellow Amarillo	0-10 V/PWM
3	Vcc	Red Rojo	DC 10V
4	FG	White Blanco	12 Pulse/R

Wiring diagram Nº 3

Nº	Signal Señal	Colour Color	Specification Especificación
1	L1	Black Negro	AC380V-50/60Hz
2	L2	Black Negro	AC380V-50/60Hz
3	L3	Black Negro	AC380V-50/60Hz
4	Pe	Yellow-Green Amarillo-Verde	

Nº	Signal Señal	Colour Color	Specification Especificación
1	Vcc	Red Rojo	DC10V
2	Vsp	Yellow Amarillo	0-10VDC/PWM
3	GND	Blue Azul	
4	FG	White Blanco	12 Pulse/R

Wiring diagram Nº 4

Nº	Signal Señal	Colour Color	Specification Especificación
1	L1	Black Negro	AC380V-50/60Hz
2	L2	Black Negro	AC380V-50/60Hz
3	L3	Black Negro	AC380V-50/60Hz
4	Pe	Yellow-Green Amarillo-Verde	

Nº	Signal Señal	Colour Color	Specification Especificación
1	Vcc	Red Rojo	DC10V
2	Vsp	Yellow Amarillo	0-10VDC/PWM
3	GND	Blue Azul	
4	FG	White Blanco	12 Pulse/R

Nº	Signal Señal	Colour Color	Specification Especificación
1	NO	Brown Marrón	NO
2	COM	Black Negro	COM
3	NC	Orange Naranja	NC

# CHARACTERISCTIC CURVE

ENKELFAN 155 EEC

## AIR FLOW - PRESSURE

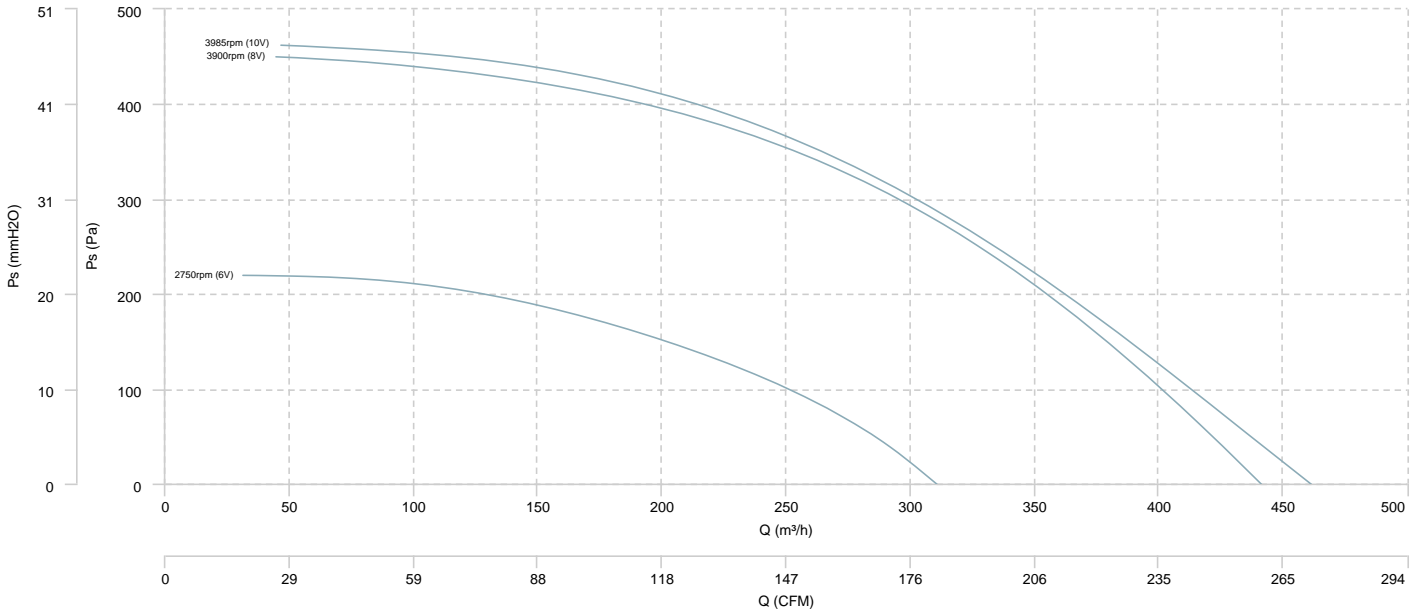

## AIR FLOW - MECHANICAL POWER

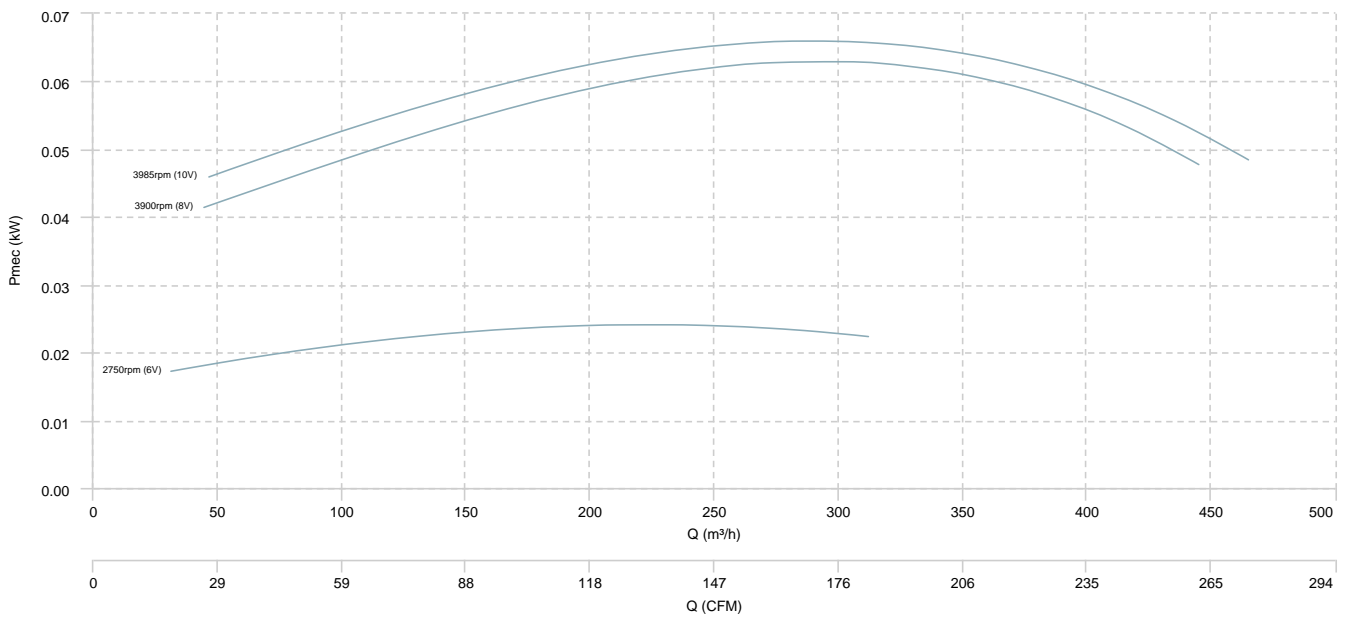

**ENKELFAN 190 EEC**

**AIR FLOW - PRESSURE**

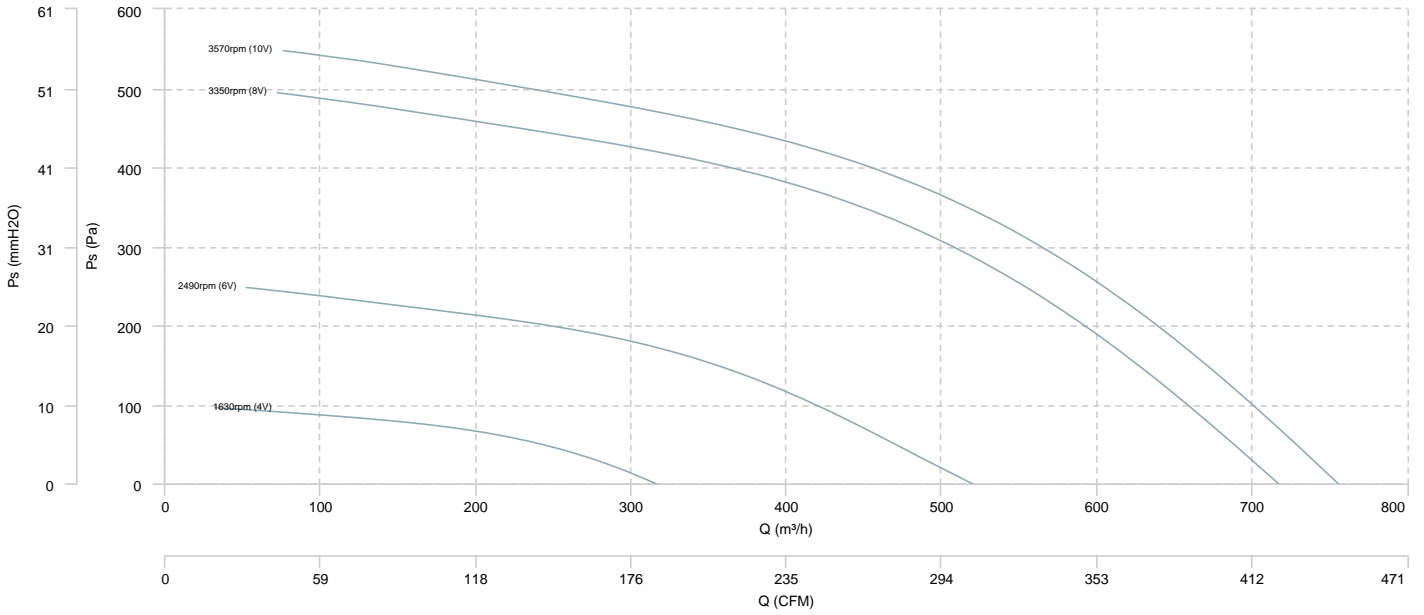

**AIR FLOW - MECHANICAL POWER**

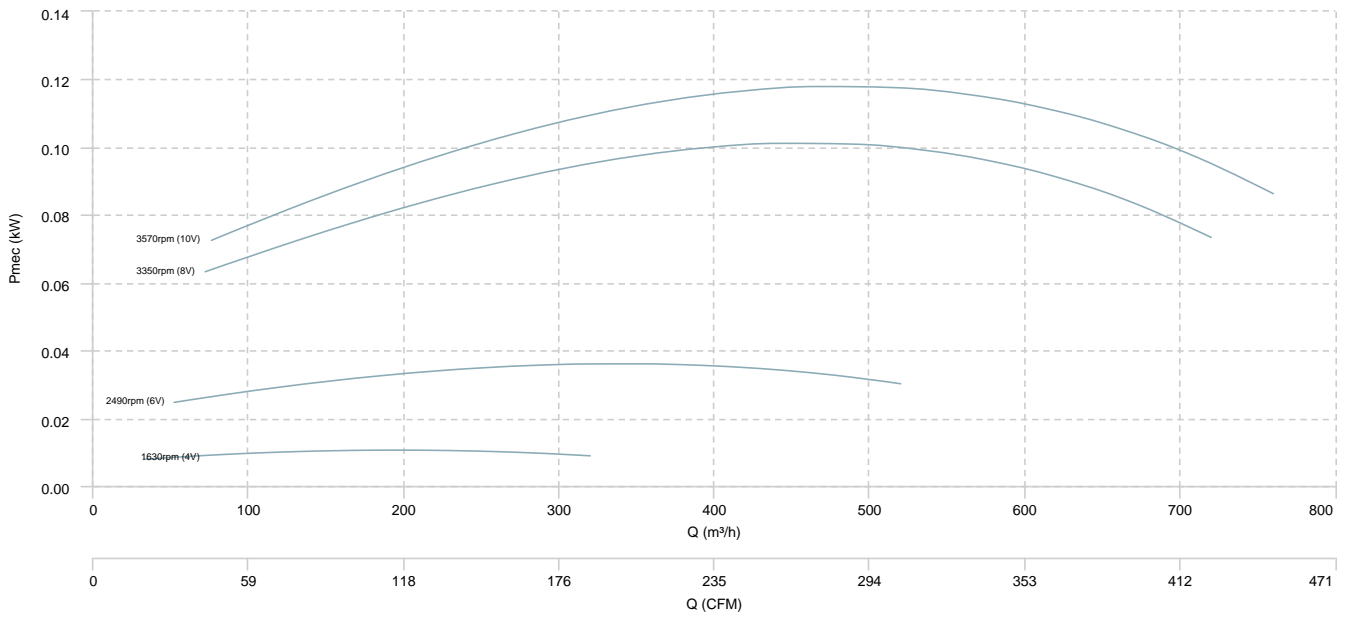

**ENKELFAN 250 EEC**

**AIR FLOW - PRESSURE**

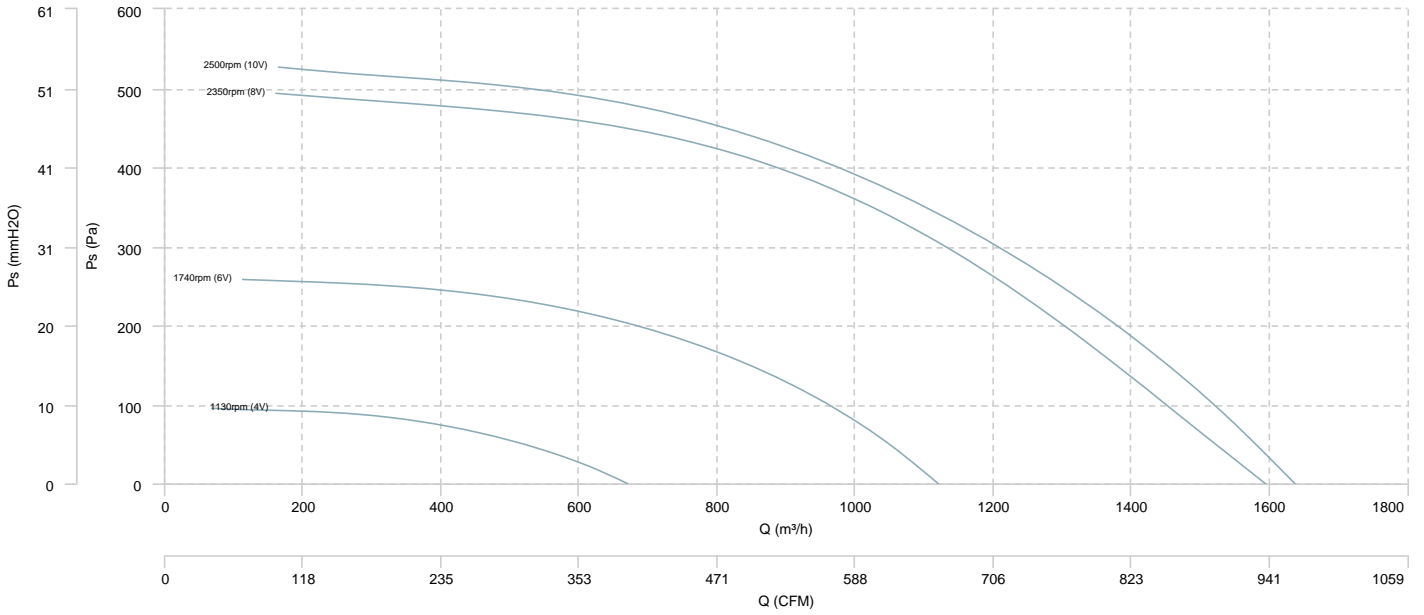

**AIR FLOW - MECHANICAL POWER**

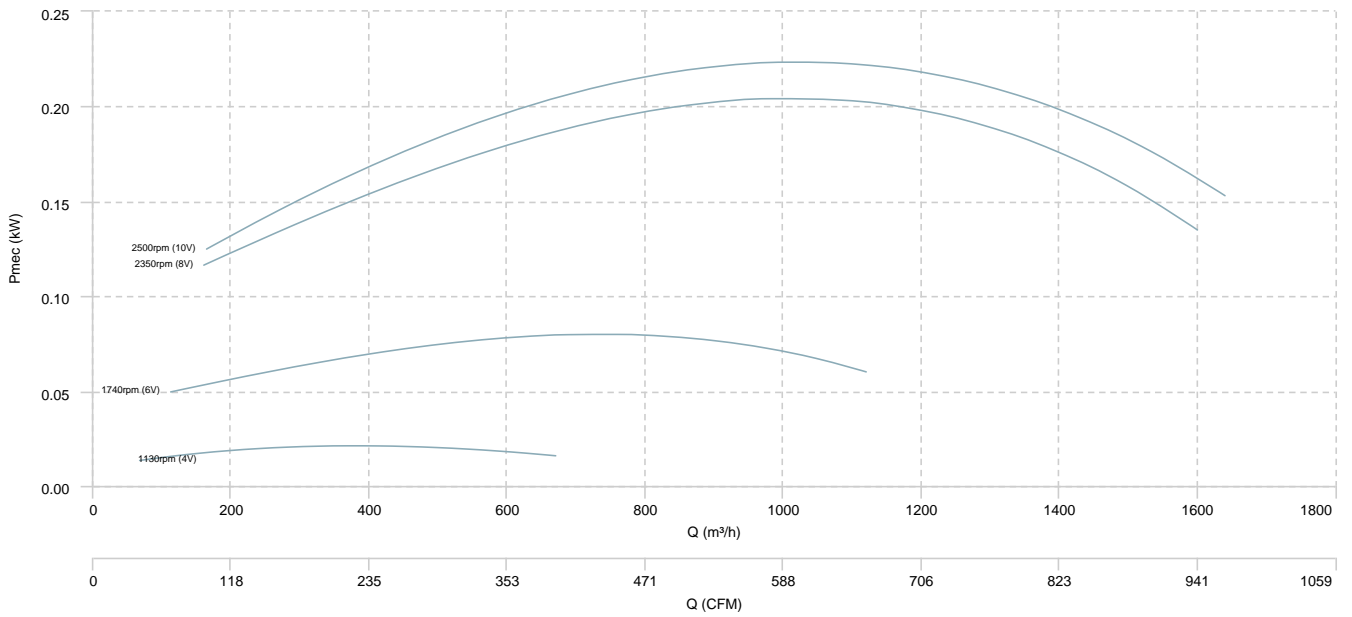



**ENKELFAN 310 EEC**

**AIR FLOW - PRESSURE**

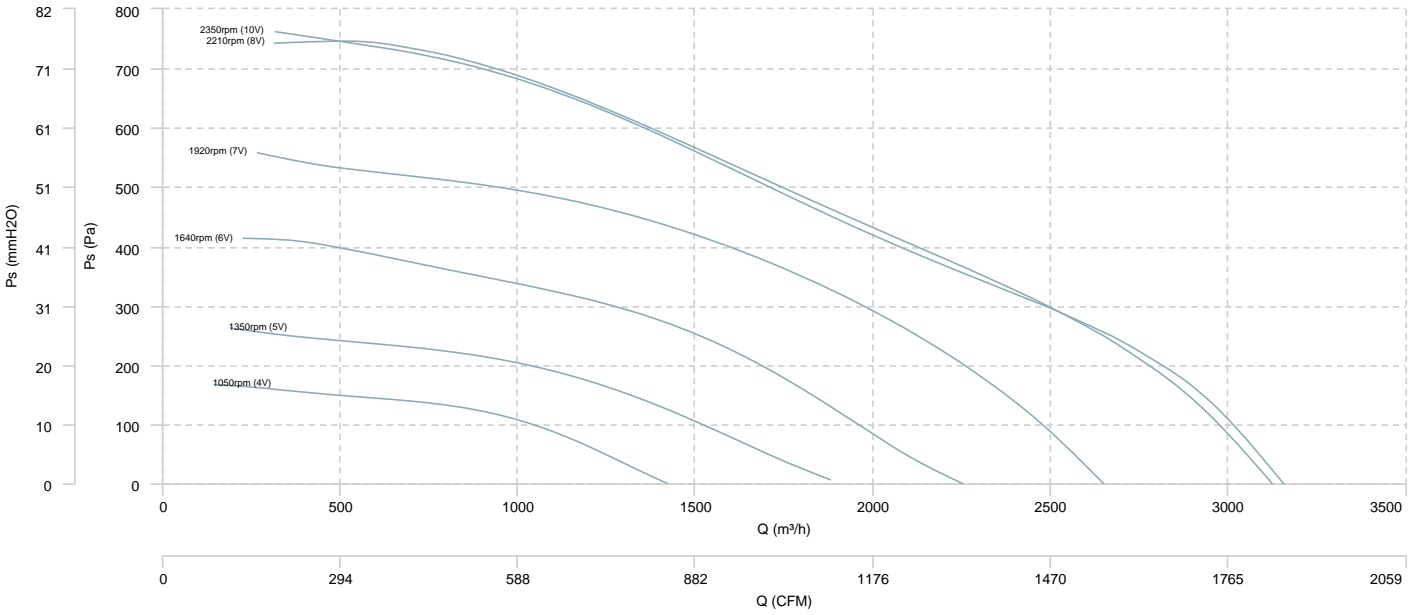

**AIR FLOW - MECHANICAL POWER**

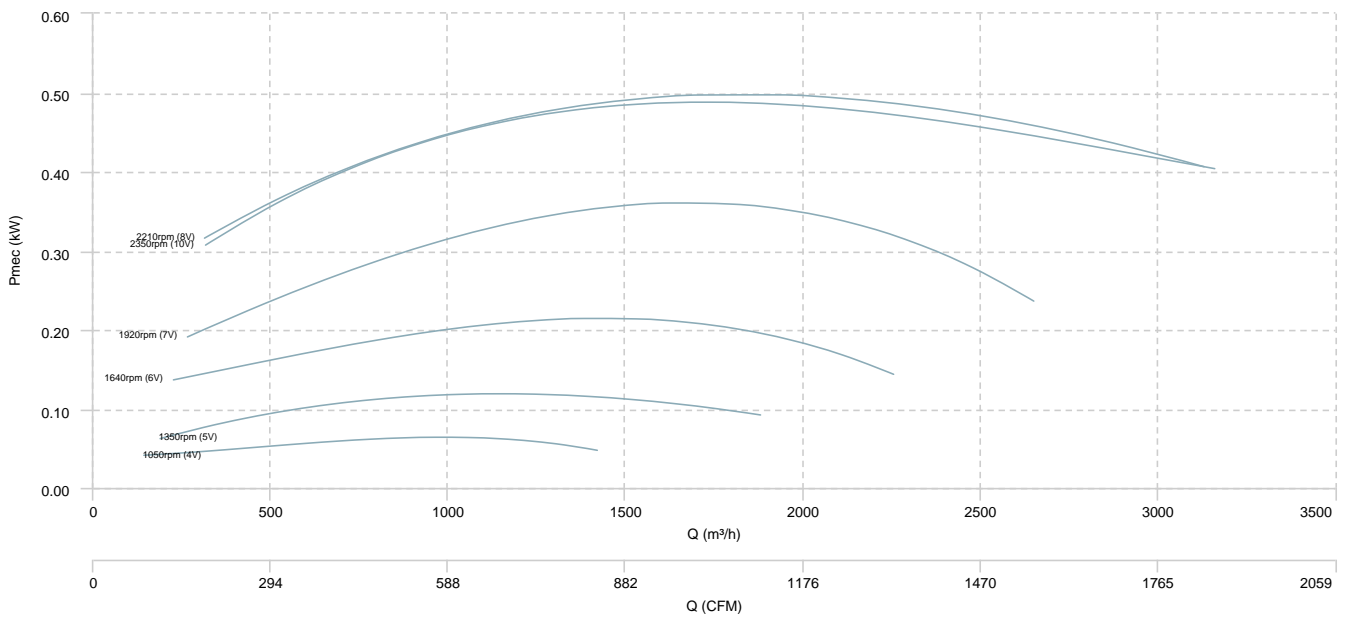

**ENKELFAN 355 EEC**

**AIR FLOW - PRESSURE**

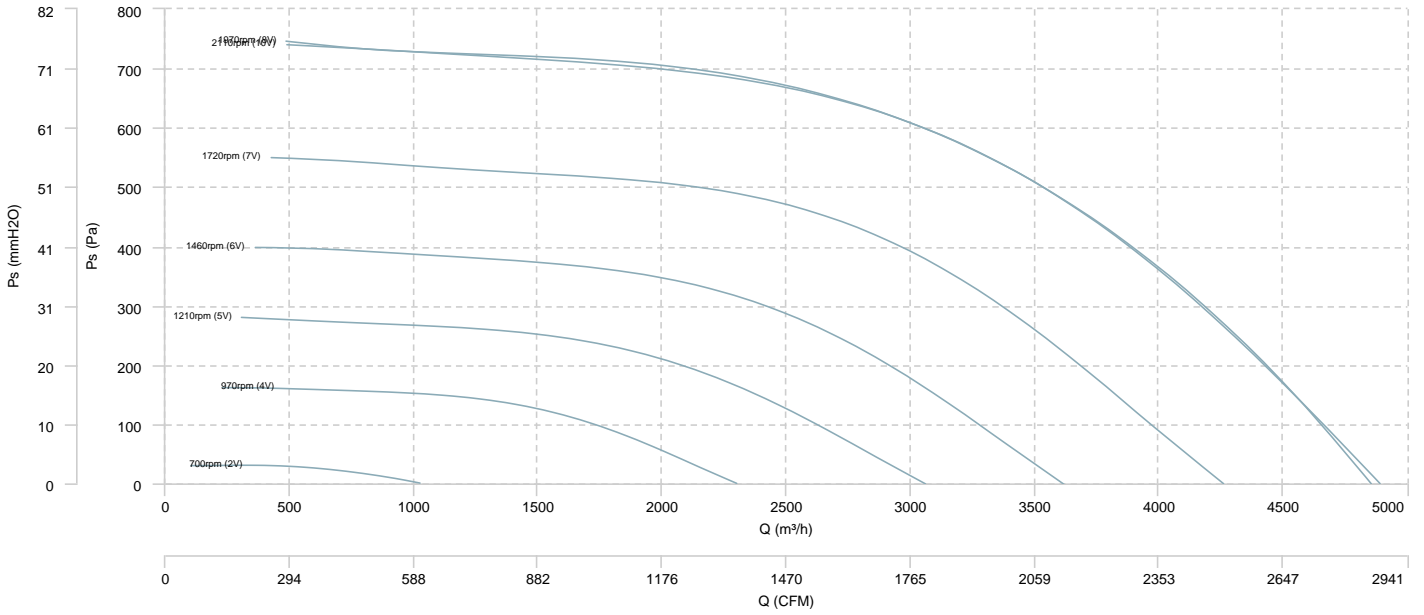

**AIR FLOW - MECHANICAL POWER**

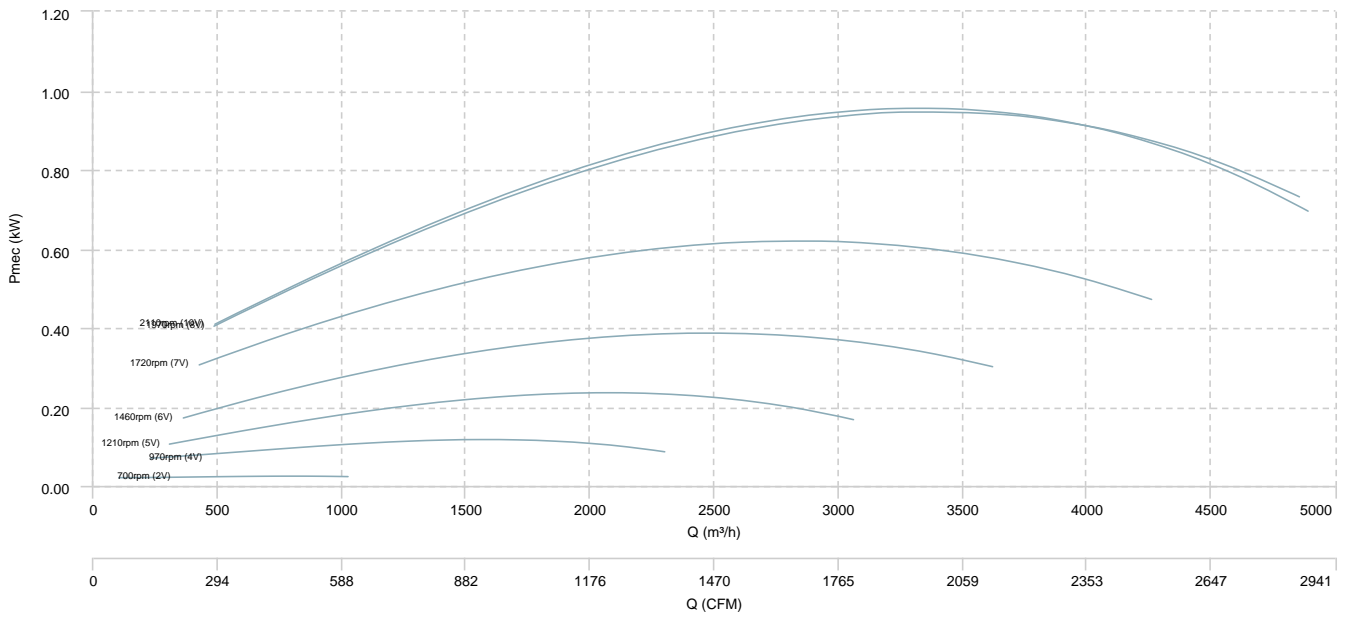

**ENKELFAN 450 EEC**

**AIR FLOW - PRESSURE**

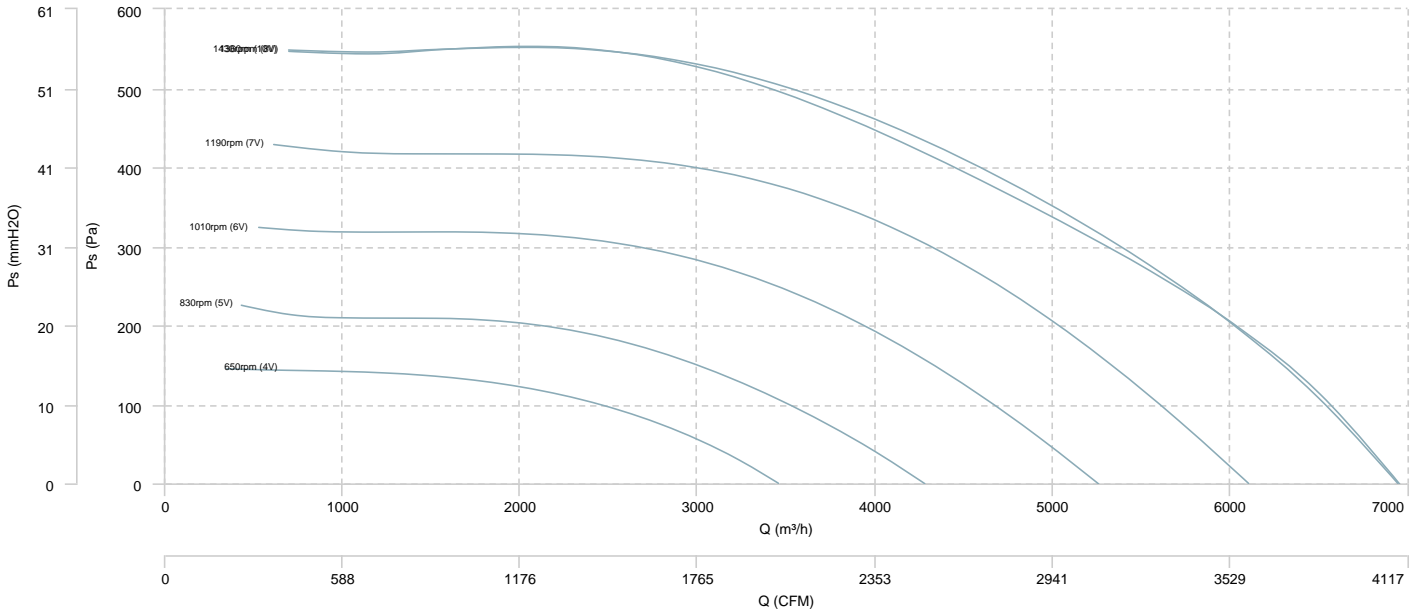

**AIR FLOW - MECHANICAL POWER**

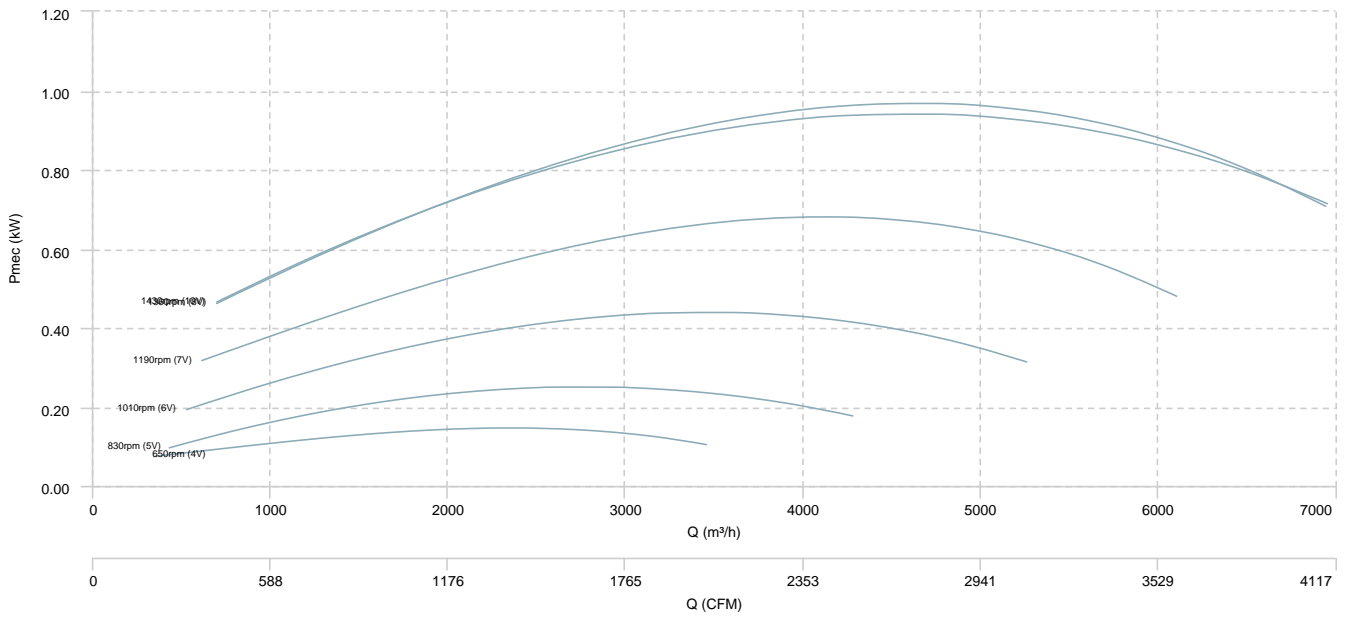

**ENKELFAN 500 EEC**

**AIR FLOW - PRESSURE**

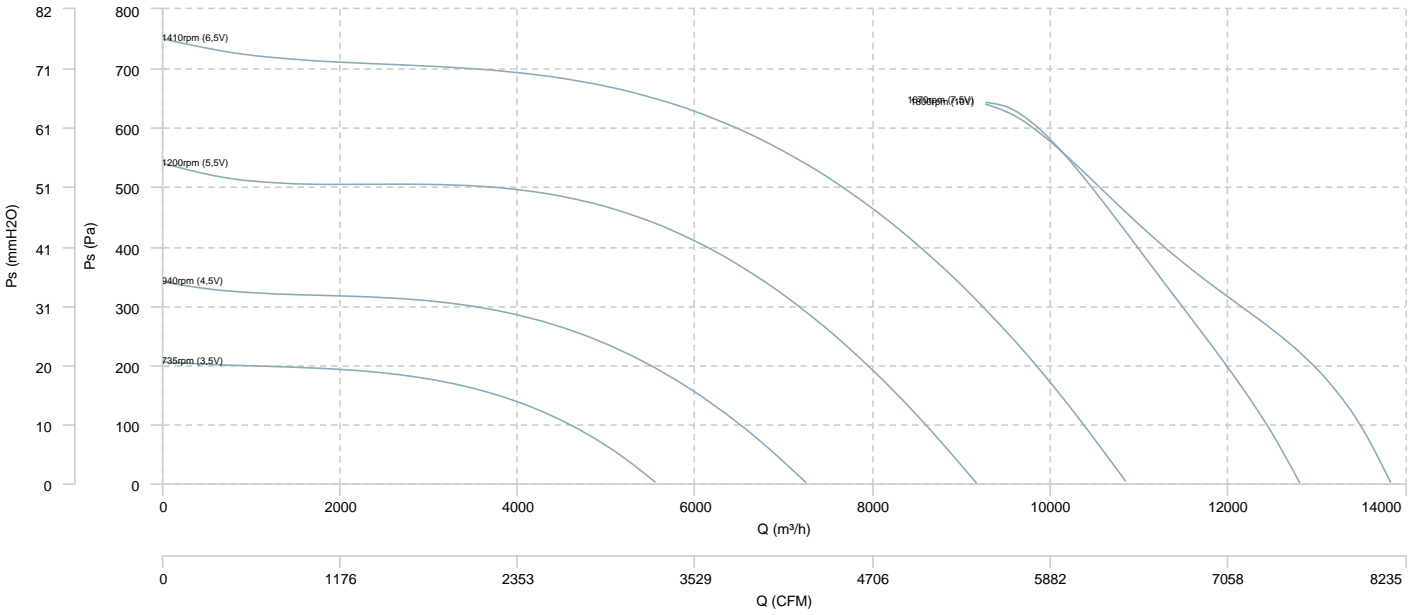

**AIR FLOW - MECHANICAL POWER**

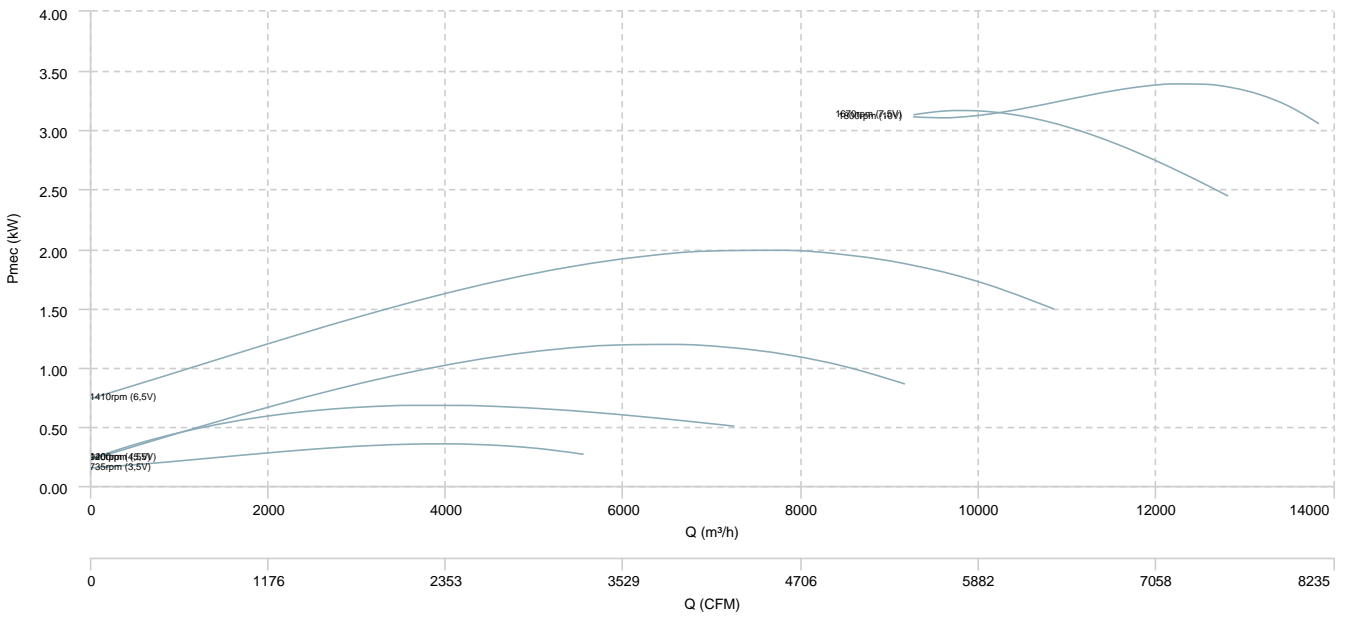

**ENKELFAN 560 EEC**

**AIR FLOW - PRESSURE**

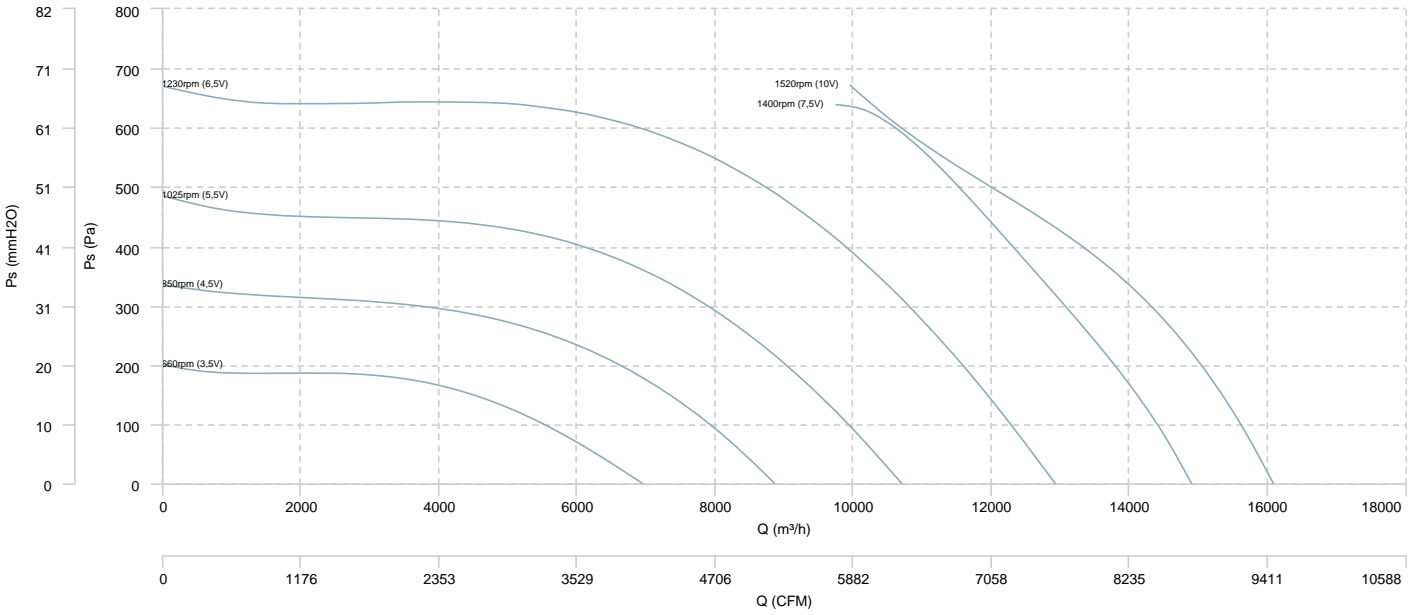

**AIR FLOW - MECHANICAL POWER**

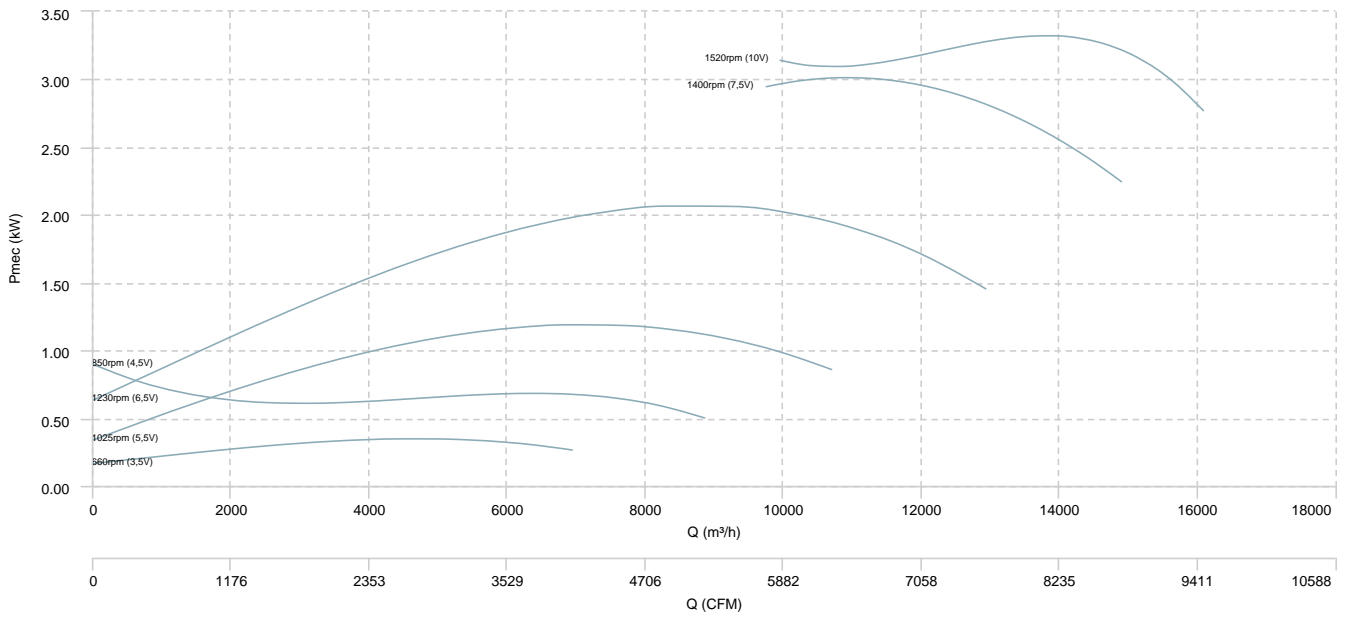

**ENKELFAN 630 EEC**

**AIR FLOW - PRESSURE**

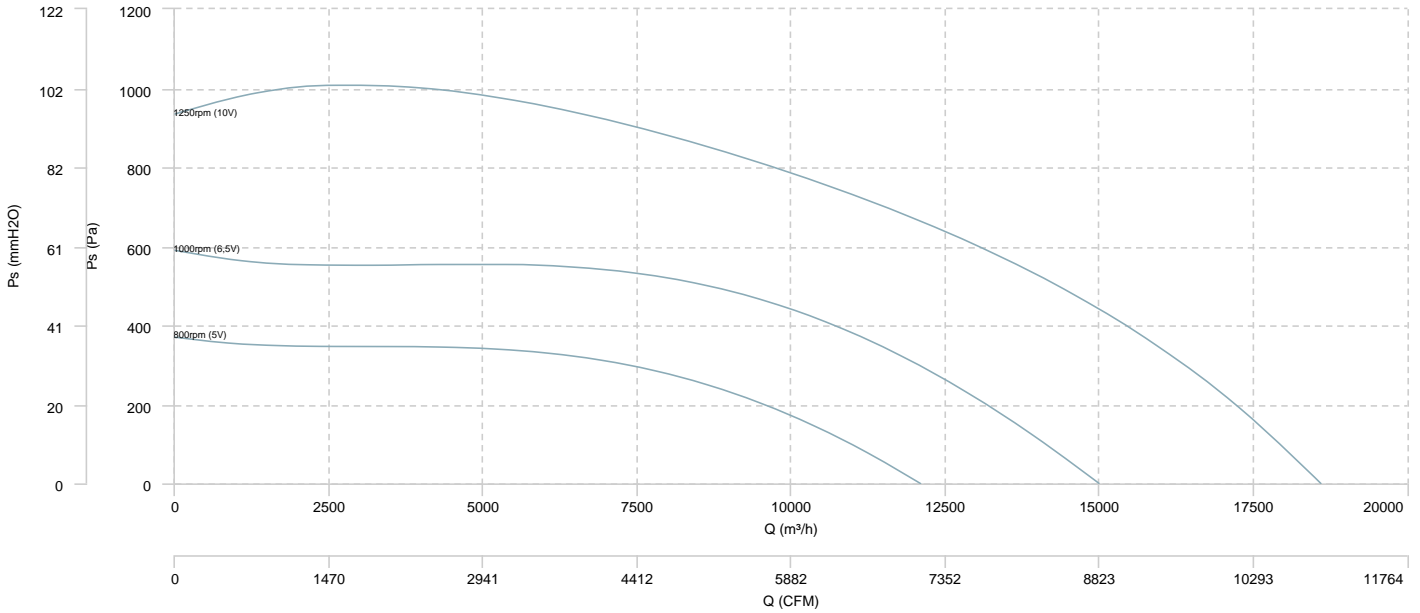

**AIR FLOW - MECHANICAL POWER**

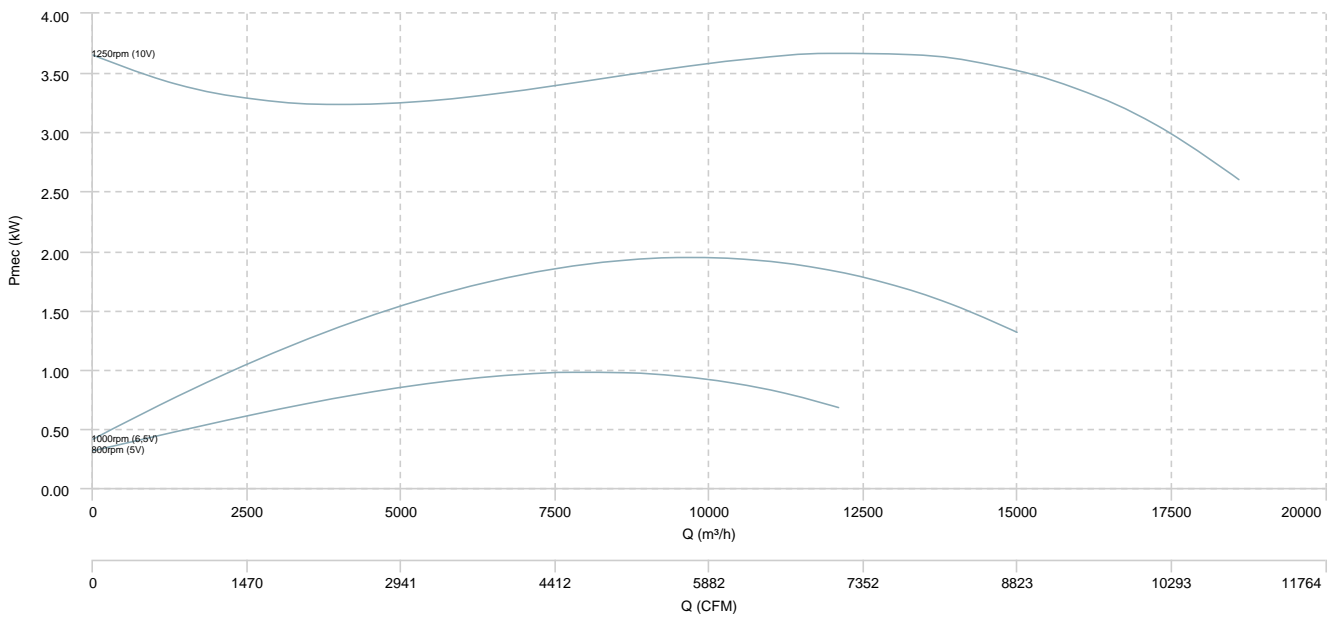

## Sound data

Sound power Lw dB (A)										
Model		63 Hz	125 Hz	250 Hz	500 Hz	1000 Hz	2000 Hz	4000 Hz	8000 Hz	Total
ENKELFAN 155 EEC (2750rpm (6V))	Radiated	32	22	39	51	56	61	51	44	63
ENKELFAN 190 EEC (1630rpm (4V))	Radiated	8	15	30	43	51	54	47	39	56
ENKELFAN 250 EEC (1130rpm (4V))	Radiated	6	20	44	51	54	53	45	31	58
ENKELFAN 310 EEC (1050rpm (4V))	Radiated	4	23	39	49	50	45	37	29	53
ENKELFAN 355 EEC (700rpm (2V))	Radiated	11	27	44	49	51	45	37	27	55
ENKELFAN 450 EEC (650rpm (4V))	Radiated	21	37	41	51	53	46	36	28	55
ENKELFAN 500 EEC (735rpm (3, 5V))	Radiated	45	46	53	57	61	65	54	41	67
ENKELFAN 560 EEC (660rpm (3, 5V))	Radiated	40	42	45	50	55	58	42	30	61
ENKELFAN 630 EEC (800rpm (5V))	Radiated	2	28	46	65	71	68	60	50	74

### Notes:

\* To calculate the sound power level at different rpm from those indicated above, use the following formula:

$$Lw \text{ dB(A)}_{rpmA} = Lw \text{ dB(A)}_{rpmB} + 52.5 \cdot \log_{10} \frac{rpmA}{rpmB}$$

## erp data

ERP	
Fan type	Centrifugal fan backward blades without casing
Installation category	A
Efficiency category	Static
The fan has to be installed with FSC	No

Model	Motor power (kW)	Maximum efficiency point data						
		Max. efficiency (%)	Efficiency grade (N) (N)	Air Flow (m³/h)	Ps (Pa)	Pabs (kW)	speed (rpm)	Specific ratio
ENKELFAN 250 EEC	0,15	50,65	68,44	899,90	395,53	0,20	2350rpm (8V)	1,00
ENKELFAN 250 EEC	0,15	50,99	68,35	942,22	411,26	0,22	2500rpm (10V)	1,00
ENKELFAN 310 EEC	0,36	50,53	68,12	1.241,40	303,72	0,21	1640rpm (6V)	1,00
ENKELFAN 310 EEC	0,36	51,65	66,81	1.624,71	392,49	0,36	1920rpm (7V)	1,00
ENKELFAN 310 EEC	0,36	52,28	65,96	1.872,80	465,14	0,50	2210rpm (8V)	1,00
ENKELFAN 310 EEC	0,36	52,68	66,46	1.865,27	455,50	0,49	2350rpm (10V)	1,00
ENKELFAN 355 EEC	0,99	50,18	67,34	1.827,44	228,40	0,23	1210rpm (5V)	1,00
ENKELFAN 355 EEC	0,99	52,89	67,80	2.132,52	334,91	0,38	1460rpm (6V)	1,00
ENKELFAN 355 EEC	0,99	54,54	67,27	2.504,34	470,08	0,61	1720rpm (7V)	1,00
ENKELFAN 355 EEC	0,99	55,54	66,37	2.934,37	618,50	0,93	1970rpm (8V)	1,01
ENKELFAN 355 EEC	0,99	55,01	65,78	2.937,14	617,82	0,94	2110rpm (10V)	1,01
ENKELFAN 450 EEC	1,01	49,76	69,11	2.026,11	121,15	0,14	650rpm (4V)	1,00
ENKELFAN 450 EEC	1,01	52,67	69,49	2.654,56	174,68	0,25	830rpm (5V)	1,00
ENKELFAN 450 EEC	1,01	56,07	70,35	3.164,80	271,70	0,44	1010rpm (6V)	1,00
ENKELFAN 450 EEC	1,01	56,32	68,65	3.603,46	366,47	0,67	1190rpm (7V)	1,00
ENKELFAN 450 EEC	1,01	56,10	66,82	4.024,81	458,51	0,95	1360rpm (8V)	1,00
ENKELFAN 450 EEC	1,01	55,34	66,17	4.043,84	442,58	0,93	1430rpm (10V)	1,00



Model	Motor power (kW)	Maximum efficiency point data						
		Max. efficiency (%)	Efficiency grade (N) (N)	Air Flow (m <sup>3</sup> /h)	Ps (Pa)	Pabs (kW)	speed (rpm)	Specific ratio
ENKELFAN 560 EEC	2,77	55,49	70,87	4.066,13	163,39	0,34	660rpm (3,5V)	1,00
ENKELFAN 560 EEC	2,77	59,96	72,28	5.497,23	254,86	0,67	850rpm (4,5V)	1,00
ENKELFAN 560 EEC	2,77	61,32	71,11	6.157,98	396,83	1,17	1025rpm (5,5V)	1,00
ENKELFAN 560 EEC	2,77	62,12	69,41	7.402,86	579,03	2,02	1230rpm (6,5V)	1,01
ENKELFAN 560 EEC	2,77	59,81	65,38	9.751	639	2,95	1400rpm (7,5V)	1,01
ENKELFAN 560 EEC	2,77	59,98	65,26	9.954	672	3,14	1520rpm (10V)	1,01
ENKELFAN 630 EEC	2,70	66,39	77,07	7.036,81	308,64	0,96	800rpm (5V)	1,00
ENKELFAN 630 EEC	2,70	66,14	73,66	8.682,84	498,80	1,92	1000rpm (6,5V)	1,00
ENKELFAN 630 EEC	2,70	64,61	69,22	11.075,89	726,16	3,64	1250rpm (10V)	1,01